

Service Bulletin

12955 Enterprise Way
Bridgeton, MO 63044-1200

Technical Service (888)GPL-LINE
Parts (800) 621-7278
Parts Fax (800) 531-2580
General Information (800) 325-8811

Issue 111

March 8, 1999

The turret baseplates in the 427 Food King have slotted holes. This allows the turret to be adjusted forward to back. The relationship between the tray half assemblies and vend doors (index 2) is crucial, to prevent the possibility of retrieving two products if the vend doors are “forced” beyond the shelf dividers. The turret baseplates (index 1) have been changed. One slot has been rotated 90 degrees to match the direction of the other 3 slots, this allows an increase to this adjustment. It is not necessary to change these baseplates on existing equipment if you are experiencing this problem. Remove the screw (index 3) from both baseplates to allow greater travel. This change will be effective in production on March 8th, 1999.

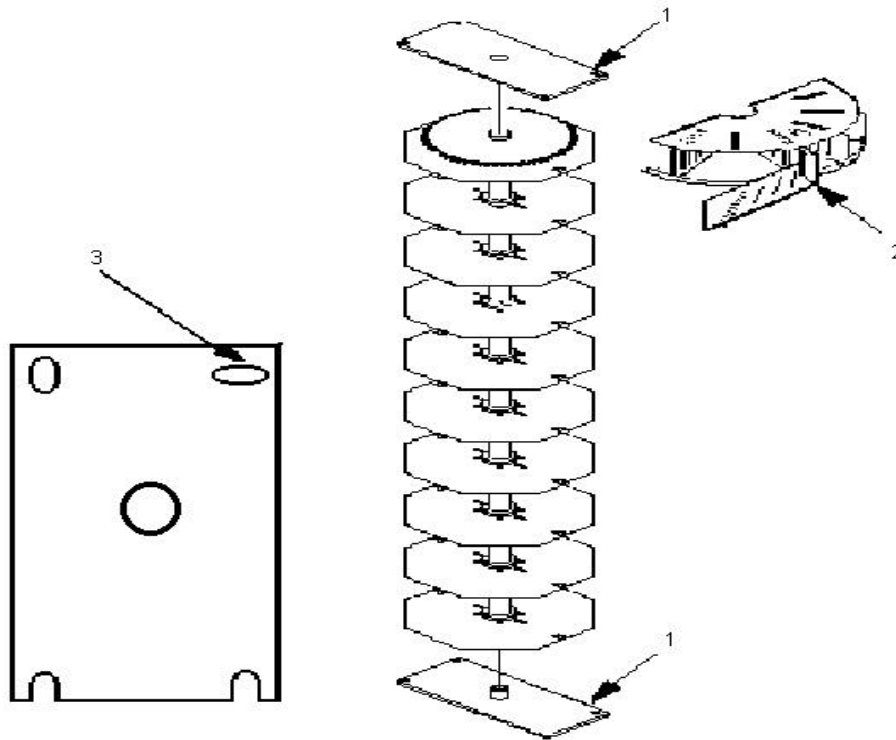

Dan Watson
GPL Service Department